

Project	Quantity	Item #
Model Specified:		CSI Section 11400

G-Series Reach-In Freezers/ Self-Contained



Equipped with an easy to use microprocessor control!



One, Two & Three Section Models, 32" Deep

Aside from their anodized aluminum side and interior finishes, Traulsen's G-Series "Dealer's Choice" models meet or exceed the standard specifications and performance of most other brands top tier product offerings. Reliable, energy efficient, and durable, with large individual storage capacities, the high quality G-Series line-up includes a wide range of one, two and three section reach-in refrigerator and freezer models, built in our most popular footprints. They are available with either full or half height doors, and the added convenience of a variety of different door hings to choose from. In addition, each also includes a number of user-friendly features, making them one of the best overall equipment values in Foodservice today, and the right fit for nearly any commercial application.

AVAILABLE MODELS

Single Section <small>(Formerly Model GLT132WUT)</small>			Two Section <small>(Formerly Model GLT232NUT)</small>			Three Section <small>(Formerly Model GLT332NUT)</small>		
Model #	Door	Hinging	Model #	Door	Hinging	Model #	Door	Hinging
G12000	Half	Right	G22000	Half	Left-Right	G31300	Half	Left-Right-Right
G12001	Half	Left	G22001	Half	Right-Left	G31301	Half	Left-Left-Right
G12010	Full	Right	G22002	Half	Right-Right	G31302	Half	Right-Right-Right
G12011	Full	Left	G22003	Half	Left-Left	G31303	Half	Left-Left-Left
			G22010	Full	Left-Right	G31310	Full	Left-Right-Right
			G22011	Full	Right-Left	G31311	Full	Left-Left-Right
			G22012	Full	Right-Right	G31312	Full	Right-Right-Right
			G22013	Full	Left-Left	G31313	Full	Left-Left-Left

Standard Product Features

- High Quality Stainless Steel Exterior Front and Door(s)
- Corrosion Resistant Anodized Aluminum One-Piece Sides
- Durable Anodized Aluminum Interior
- Microprocessor Control With LED Temperature Readout
- Top-Mounted, Balanced, Self-Contained Refrigeration System
- Minus 10 Degree F Capable
- Large High Humidity Evaporator Coil Outside The Food Zone
- Load-Sure Guard Protects Against Improper Loading
- Full or Half Length Stainless Steel Doors With Locks
- Self-Closing Doors With Stay Open Feature At 120 Degrees
- Guaranteed For Life Cam-Lift Hinges
- Guaranteed For Life Horizontal Work Flow Door Handle(s)
- Automatically Activated Incandescent Lights
- Damage Resistant Stainless Steel Breaker Caps
- Three (3) Adjustable Epoxy Coated Shelves Per Section, Supported On Shelf Pins (installed at the factory)
- Energy Saving Automatic Non-Electric Condensate Evaporator
- Magnetic Snap-In Door Gaskets
- Gasket Protecting Anodized Aluminum Door Liner
- Anti-Condensate Door Perimeter Heaters
- Thermostatic Expansion Valve Metering Device Provides Quick Refrigeration Recovery Times
- Stainless Steel One-Piece Louver Assembly
- 9' Cord & Plug Attached
- Set of Four (4) 6" High Casters With Locks
- One Year Parts And Labor Warranty
- Five Year Compressor Warranty

Optional Accessory Kits

- Additional Epoxy Coated Shelves*
- No. 1 Type Tray Slides* To Accommodate either: (1) 18" x 26" or (2) 14" x 18" Sheet Pans, Adjustable To 2" O.C.
- No. 4 Type Tray Slides* To Accommodate (1) 18" x 26" Sheet Pans (equips one full section)
- Universal Type Tray Slides* To Accommodate Either (1) 18" x 26" or (2) 14" x 18" Sheet Pans, or (2) 12" x 20" Steam Table Pans, Adjustable To 4" O.C.
- Chrome Plated Shelves* (for use in lieu of standard shelving)
- 6" High Adjustable Legs (for use in lieu of standard casters)
- Two Year Service/Labor Warranty Available

***Please refer to spec sheet 4-7 for optional accessory kit details**

NOTE: All optional accessory kits are shipped separately for later installation by others at the jobsite.

All 1 and 2 Section G-Series solid door freezer models are ENERGY STAR® Version 2 listed for efficient operation (effective Jan. 1, 2010).



Listed by Underwriters Laboratories Inc., to U.S. and Canadian safety standards and Listed by NSF International.

Approval: _____



TRAULSEN
4401 BLUE MOUND RD.
PHONE 1 (800) 825-8220
Website: www.traulsen.com

FT. WORTH, TX 76106
FAX-MKTG. 1 (817) 624-4302

Project	Quantity	Item #
Model Specified:		CSI Section 11400

Specifications

Construction, Hardware and Insulation

Cabinet exterior front, louver assembly and doors are constructed of 20 gauge stainless steel. Cabinet sides (including returns), interior and door liners are constructed of anodized aluminum. The exterior cabinet top, back and bottom are constructed of heavy gauge aluminized steel. A set of four (4) 6" high casters are included.

Doors are equipped with a gasket protecting metal door pan, removable plug cylinder locks and guaranteed for life cam-lift, gravity action, self-closing metal, glide hinges with stay open feature at 120 degrees. Hinges include a concealed switch to automatically activate the interior incandescent lighting. Guaranteed for life, work flow door handles are mounted horizontally over recess in door which limits protrusion from door face into aiseways.

Easily removable for cleaning, vinyl magnetic door gasket assures tight door seal. Anti condensate heaters are located behind each door opening.

Both the cabinet and door(s) are insulated with an average of 2" thick high density, non-CFC, foamed in place polyurethane.

DIMENSIONAL DATA	1-Section Models	2-Section Models	3-Section Models
Net capacity cu. ft.	24.2 (686 cu l)	46.0 (1303 cu l)	69.1 (1958 cu l)
Length - overall in.	29 ⁷ / ₈ (75.9 cm)	52 ¹ / ₂ (132.4 cm)	76 ⁵ / ₈ (193.8 cm)
Depth - overall in.	35 (88.8 cm)	35 (88.8 cm)	35 (88.8 cm)
Depth - over body in.	32 (81.3 cm)	32 (81.3 cm)	32 (81.3 cm)
Depth - door open 90° in.	57 ⁵ / ₈ (146.3 cm)	57 ⁵ / ₈ (146.3 cm)	57 ⁵ / ₈ (146.3 cm)
Clear door width in.	21 ¹ / ₈ (53.6 cm)	21 ¹ / ₈ (53.6 cm)	21 ¹ / ₈ (53.6 cm)
Clear half-door height in.	27 ¹ / ₂ (69.9 cm)	27 ¹ / ₂ (69.9 cm)	27 ¹ / ₂ (69.9 cm)
Clear full-door height in.	57 ⁵ / ₈ (146.3 cm)	57 ⁵ / ₈ (146.3 cm)	57 ⁵ / ₈ (146.3 cm)
Height-overall on 6" casters	83 ³ / ₄ (211.5 cm)	83 ³ / ₄ (211.5 cm)	83 ³ / ₄ (211.5 cm)
No. Standard Shelves	3	6	9
Shelf area sq. ft. ¹	18.8 (1.75 sq m)	34.6 (3.21 sq m)	51.9 (4.82 sq m)
ELECTRICAL DATA			
Voltage	115/60/1	115/60/1	208-230/115/60/1
Feed wires with Ground	3	3	4
Full load amperes	9.5	11.2	11.0
REFRIGERATION DATA			
Refrigerant	R-404A	R-404A	R-404A
BTU/HR H.P. ²	1930 (½ HP)	2970 (¾ HP)	4710 (1 HP)
SHIPPING DATA			
Length - crated in.	35 (89 cm)	63 (160 cm)	91 (231 cm)
Depth - crated in.	43 (109 cm)	43 (109 cm)	43 (109 cm)
Height - crated in.	83 ¹ / ₂ (212 cm)	83 ¹ / ₂ (212 cm)	83 ¹ / ₂ (212 cm)
Volume - crated cu. ft.	71 (2011 cu l)	131 (3711 cu l)	189 (5354 cu l)
Net Wt. lbs.	320 (145 kg)	650 (295 kg)	690 (313 kg)
Gross Wt. lbs.	410 (186 kg)	700 (318 kg)	870 (395 kg)

NOTES

NOTE: Figures in parentheses reflect metric equivalents.

- Figure shown reflects the area of standard shelf complement plus the additional storage area available on the cabinet bottom.
- Based on a 90 degree F ambient and -20 degree F evaporator. For remote data please refer to spec sheet 13-2.

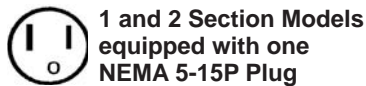

REQUIRED CLEARANCES

In order to assure optimum performance, the condensing unit **MUST** have an adequate supply of air for cooling purposes. Therefore, the operating location must either have a minimum of 12" clearance overhead of the condensing unit or allow for unrestricted air flow at the back of the unit. Clearance of at least 12" above is required in order to perform certain maintenance tasks.

NOTE: When ordering please specify: Voltage, Hinging, Door Size, Options and any additional warranties.

Continued product development may necessitate specification changes without notice.
Part No. TR35788 (revised 11/09)

Refrigeration System

A top mounted, self-contained, balanced refrigeration system using R-404A refrigerant is conveniently located behind the one piece louver assembly. It features an easy to clean front facing condenser, thermostatic expansion valve, air-cooled, hermetic compressor, large, high humidity evaporator coil located outside the food zone and a top mounted non-electric condensate evaporator. A 9' cord and plug is provided. Standard operating temperature is 0 to -5°F (all models are -10 degree F capable in up to 90 degree ambient).

Controller

The easy to use water resistant microprocessor control system is supplied standard. It includes a 3-Digit LED Display, and a Fahrenheit or Celsius Temperature Scale Display Capability.

Interior

Standard interior arrangements include three (3) epoxy coated wire shelves per section, mounted on shelf pins, installed at the factory. Shelves are full-width, and do not have any large gaps between them requiring the use of "bridge" or "junior shelves." Recommended load limit per shelf should not exceed 225 lbs.

Warranties

Both a one year parts and labor warranty and a five year compressor warranty (self-contained models only) are provided standard. An optional 2nd year extended parts and labor warranty is also available.

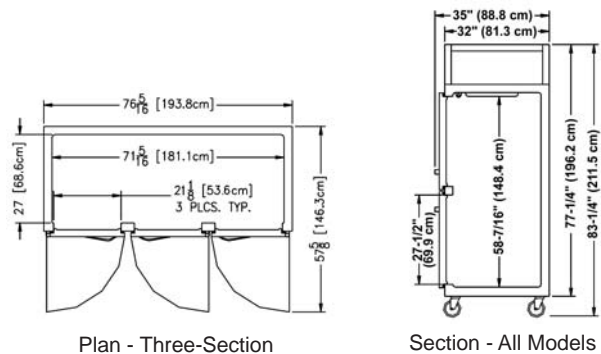
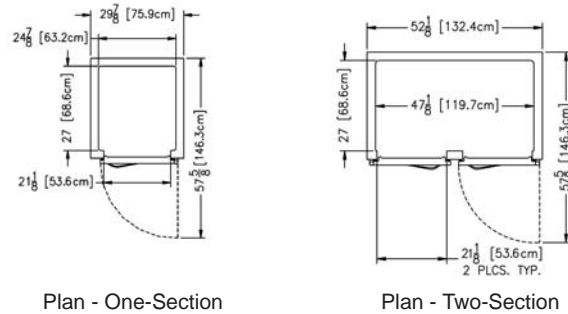
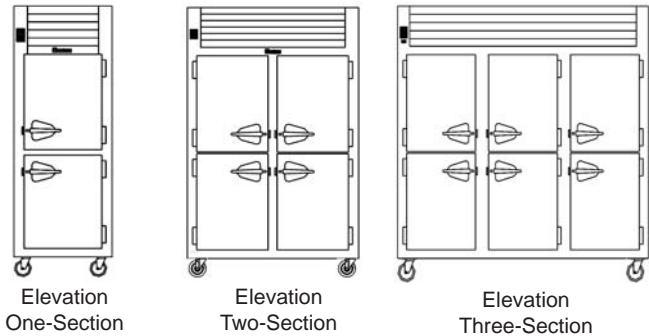

TRAUlsen
4401 BLUE MOUND RD.
PHONE 1 (800) 825-8220
Website: www.traulsen.com

FT. WORTH, TX 76106
FAX-MKTG. 1 (817) 624-4302

